

APPLICATION:

PRODUCT NAME:

**4" C/C BACKSPLASH FAUCET
WITH RIGID GOOSENECK SPOUT**

JOB NAME:

_____ SPECIAL CONFIGURATION
(CHECK BASE MODEL AND OPTIONS)

QUANTITY:

ITEM NO.:

MODEL:

- 3616 4" C/C BACKSPLASH W/ 12" RGN
- 2003 4" C/C BACKSPLASH W/ 6" RGN

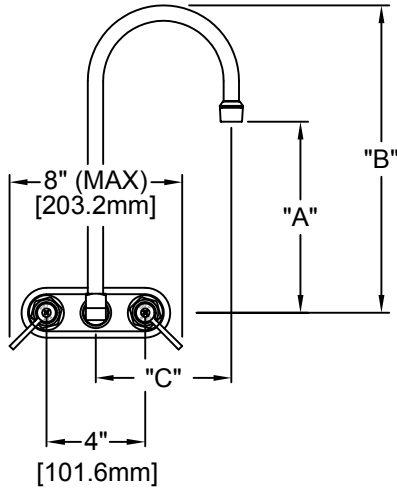

MODEL	DIM "A"	DIM "B"	DIM "C"
3616	8-3/4" [222.3mm]	12-1/2" [317.5mm]	5-1/2" [139.7mm]
2003	5" [127.0mm]	8-3/4" [222.3mm]	3-1/2" [88.9mm]

OPTIONS OR MODIFICATIONS:

- SUPPLY LINES (24" OR 36") CIRCLE LENGTH
- IN-LINE DUAL CHECK VALVE
- ELBOWS
- VANDAL RESISTANT KIT
- HANDLES (CROSS OR WRIST) CIRCLE STYLE
- OTHER _____

FEATURES:

CONTROL VALVE

- * 4" C/C BACKSPLASH
- * INTERNAL SPRING LOADED CHECK VALVES
- * SWIVELING SEAT DISKS
- * HOT SIDE STEM - LEFT HAND
- * COLD SIDE STEM - RIGHT HAND
- * STAINLESS STEEL SEATS
- * STAINLESS STEEL SEAT SCREWS
- * STAINLESS STEEL HANDLE SCREWS
- * 1/2" SLIP JOINT KIT INCLUDED

SYSTEM LIMITS

- * TEMP: 40°F MIN. TO 140°F MAX.
- * PRESSURE 200 PSI MAX. STATIC
- * 2.2 GPM AT 80 PSI

SHIPPING WEIGHT

- * 4.5 LBS

ROUGH-IN:

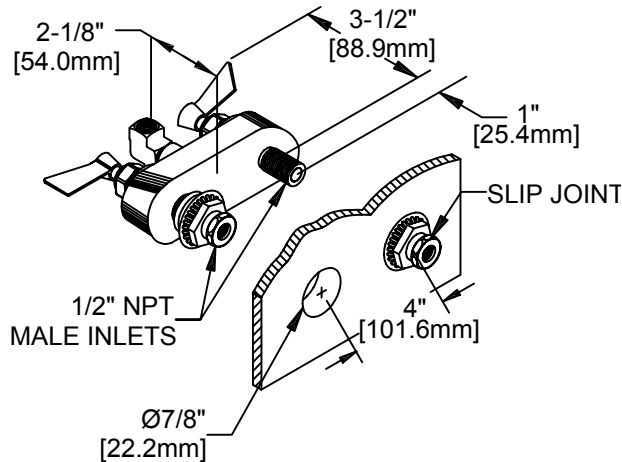

ANSI/A112.18.1M, ANSI/NSF 61.9



FISHER MANUFACTURING COMPANY
TOLL FREE: 800-421-6162 - FAX: 800-832-8238
information@fisher-mfg.com - www.fisher-mfg.com